

# DTR with grinder



DTR 150-300



DTRT 400-1000



DTRT 400-1000/P



Trituratore  
Grinder  
Triturador  
Triturateur

Pompe da drenaggio con girante centrifuga che garantisce una elevata prevalenza.

Il sistema **tritratore** permette il pompaggio di liquami con fibre tessili o filamentose, liquami industriali, civili e zootecnici dove si renda necessario frantumare solidi in sospensione; disponibili sia per applicazioni mobili e fissa con piede di accoppiamento.

Centrifugal drainage pump that guarantees high head. The **grinder** allows to pumps sewage containing textile or filamentous fibres, industrial, civil and zootecnical sewage whenever suspended solids have to be crushed; available in the mobile or permanent versions with coupling feet.

Bombas de drenaje con rodete centrífugo que garantiza una elevada prevalencia. El sistema **tritratador** permite el bombeo de aguas sucias con fibras textiles o filamentosas, líquidos industriales, civiles y zootécnicos donde se necesita triturar cuerpos, sólidos en suspensión; disponibles para aplicaciones móviles y fija con pie de acoplamiento.

Pompes de drainage avec une roue centrifuge qui garantit une hauteur manométrique élevée.

Le système **tritrateur** permet le pompage de purin avec fibres textiles ou filamenteuses, purin industriel, civil et zootecnique où il est nécessaires de briser des solides en suspension; disponibles pour applications aussi bien mobiles que fixes, avec pied d'accouplement.

## CARATTERISTICHE COSTRUTTIVE / CONSTRUCTION FEATURES CARACTERÍSTICAS CONSTRUCTIVAS / CARACTÉRISTIQUES D'EXÉCUTION

<b>Corpo pompa</b> <b>Pump body</b> <b>Cuerpo bomba</b> <b>Corps de pompe</b>	ghisa cast iron fundición fonte
<b>Girante</b> <b>Impeller</b> <b>Rodete</b> <b>Turbine</b>	ghisa cast iron fundición fonte
<b>Tenuta meccanica</b>	doppia tenuta con barriera d'olio:carburo di silicio lato pompa, ceramica-grafite lato motore
<b>Mechanical seal</b>	double seal with oil barrier: silicon carbide on pump side, ceramic-graphite on motor side
<b>Sello mecánico</b>	doble sello con cámara interpuesta:carburo de silicio lato bomba, cerámica-grafito lato motor
<b>Garniture mécanique</b>	double garniture avec film lubrifiant:carbure de silice côté pompe, céramique-graphite côté moteur
<b>Albero motore</b> <b>Motor shaft</b> <b>Eje motor</b> <b>Arbre moteur</b>	acciaio AISI 304 stainless steel AISI 304 acero AISI 304 acier AISI 304
<b>Profondità di immersione</b> <b>Depth of immersion</b> <b>Profundidad inmersión</b> <b>Profondeur immersion</b>	max 20 m
<b>Temperatura del liquido</b> <b>Liquid temperature</b> <b>Temperatura del líquido</b> <b>Température du liquide</b>	0 - 40 °C
<b>Cavo</b> <b>Cable</b> <b>Cable</b> <b>Câble</b>	H07 RNF, 10 m
<b>Trituratore</b> <b>Grinder</b> <b>Triturador</b> <b>Triturateur</b>	acciaio inossidabile trattato treated stainless steel acero tratado acier traité
<b>Viteria</b> <b>Bolts</b> <b>Tornillos</b> <b>Vis</b>	acciaio inossidabile A2 A2 stainless steel acero A2 acier A2
<b>Base appoggio</b> <b>Foot support</b> <b>Placa base</b> <b>Plaque de base</b>	ferro zincato galvanized iron hierro galvanizado fer galvanisé
<b>Guarnizioni</b> <b>Gaskets</b> <b>Anilos</b> <b>Joints</b>	gomma NBR NBR rubber goma NBR caoutchouc NBR
<b>MOTORE / MOTOR / MOTOR / MOTEUR</b>	
<b>Motore 2 poli a induzione in bagno d'olio</b>	3~ 230/400V-50Hz P ≤ 4kW 3~ 400/690V-50Hz P > 4kW
<b>2 pole induction motor in oil bath</b>	1~ 230V-50Hz necessario condensatore d'avviamento (35µF per modello da 1,5HP, 50µF per modello da 2HP)
<b>Motor de 2 polos a inducción en baño de caeite</b>	required starter capacitor (35µF for 1,5HP model, 50µF for 2HP model)
<b>Moteur à induction à 2 pôles en bain d'huile</b>	necessario condensador de arranque (35µF para modelo 1,5HP, 50µF para modelo 2HP)
<b>Classe di isolamento</b> <b>Insulation class</b> <b>Clase de aislamiento</b> <b>Classe d'isolation</b>	F
<b>Grado di protezione</b> <b>Protection degree</b> <b>Grado de protección</b> <b>Protection</b>	IP68

# DTR with grinder

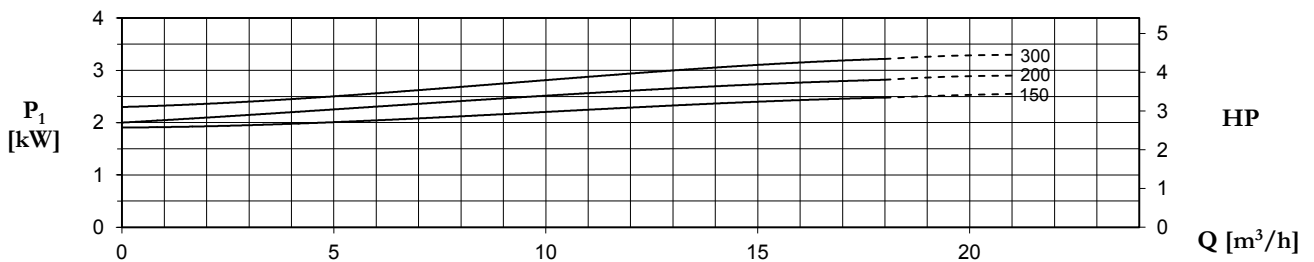
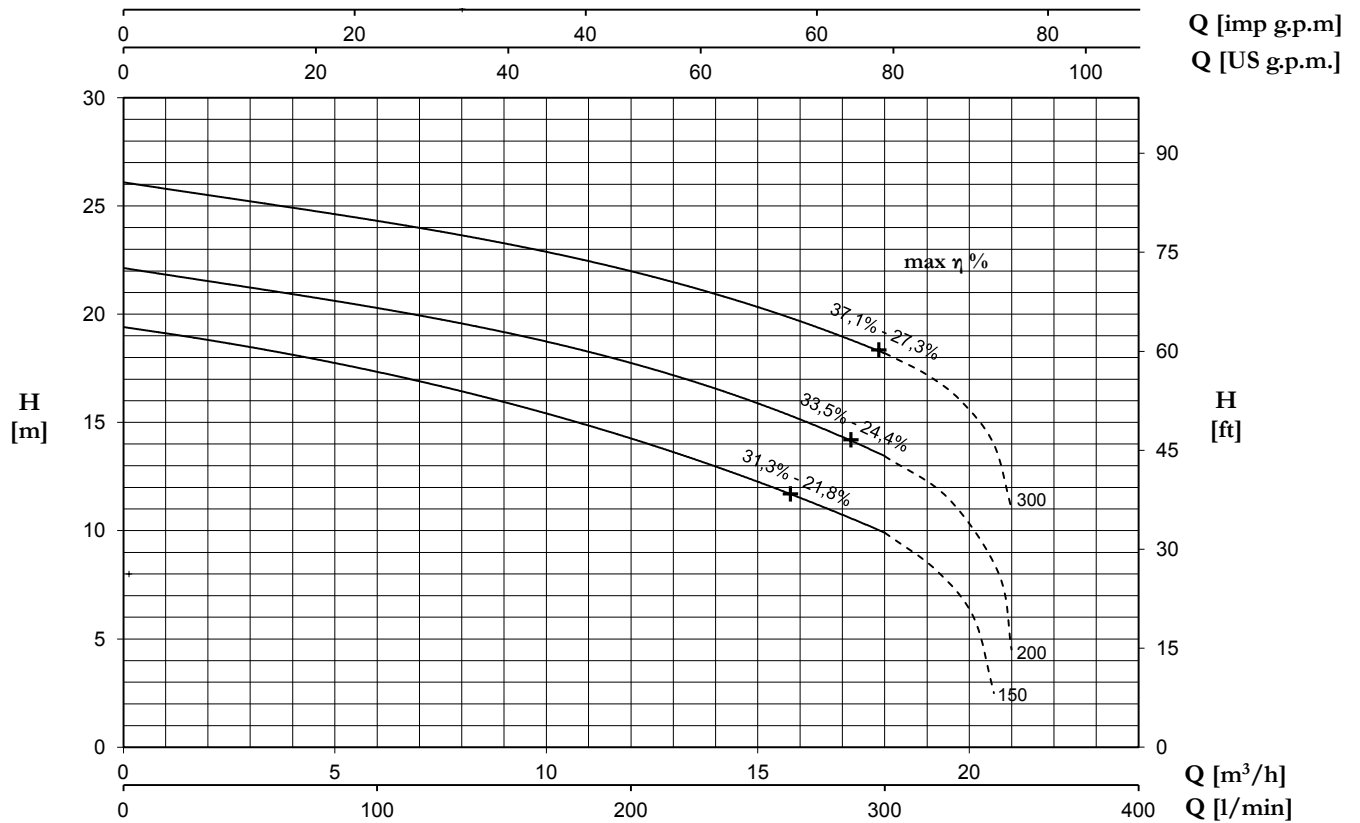

TYPE		AMPERE				
1~	3~	230 V 50 Hz	3x230 V 50 Hz (*)	3x400 V 50 Hz	230/400 V 50 Hz λ / Δ (*)	400/690 V 50 Hz λ / Δ
DTR 150	DTRT 150	11,5	7,6	4,4	-	-
DTR 200	DTRT 200	13,6	8,8	5,1	-	-
-	DTRT 300	-	10,0	5,8	-	-

**+ max η %**

max rendimento idraulico e rispettivo rendimento totale  
 max hydraulic efficiency and respective total efficiency  
 máx rendimiento hidráulico y correspondiente rendimiento total  
 max rendement hydraulique et rendement total

(\*) no standard execution

TYPE		P2		P1 (kW)		Q (m³/h - l/min)						
1~	3~	P2		P1 (kW)		0	3	6	9	12	15	18
		(HP)	(kW)	1~	3~	0	50	100	150	200	250	300
						H (m)						
DTR 150	DTRT 150	1,5	1,1	2,6	2,5	19,4	18,5	17,3	16,0	14,2	12,3	9,9
DTR 200	DTRT 200	2	1,5	3,0	2,8	22,1	21,3	20,3	19,1	17,7	16,0	13,4
-	DTRT 300	3	2,2	-	3,2	26,1	25,2	24,3	23,3	22,0	20,3	18,2

# DTR with grinder

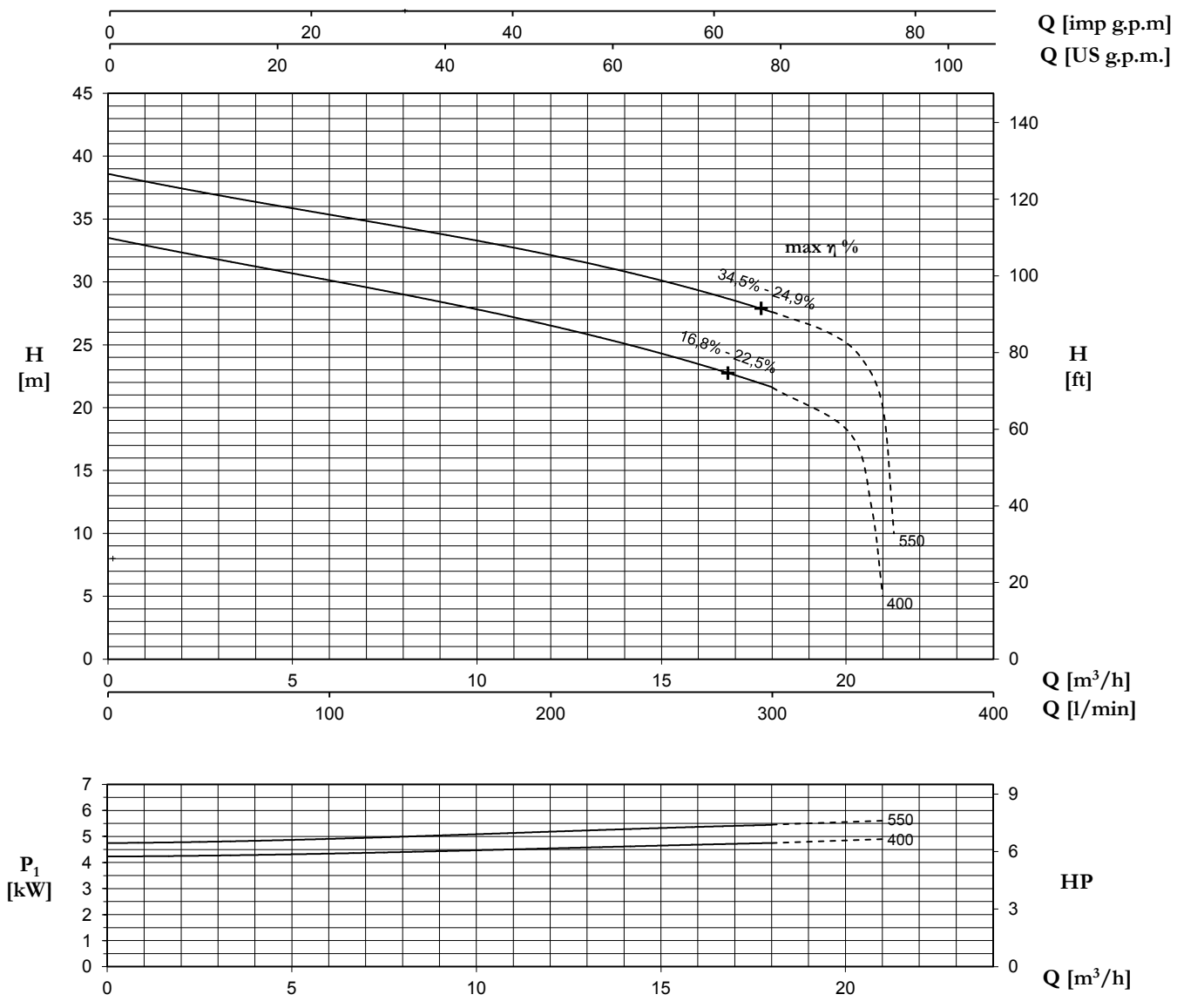

TYPE	AMPERE			
	3x230 V 50 Hz (*)	3x400 V 50 Hz	230/400 V 50 Hz λ / Δ (*)	400/690 V 50 Hz λ / Δ
DTRT 400	13,0	7,5	-	-
DTRT 550	15,9	9,2	-	-

(\*) no standard execution

## + max η %

max rendimento idraulico e rispettivo rendimento totale  
 max hydraulic efficiency and respective total efficiency  
 máx rendimiento hidráulico y correspondiente rendimiento total  
 max rendement hydraulique et rendement total

TYPE	P2			P1 (kW)	Q (m³/h - l/min)						
					H (m)						
					0	3	6	9	12	15	18
3~	(HP)	(kW)	3~	0	50	100	150	200	250	300	
DTRT 400	4	3	4,5	33,5	31,8	30,1	28,5	26,4	24,4	21,6	
DTRT 550	5,5	4	5,3	38,6	36,9	35,3	33,9	32,1	30,1	27,6	

# DTR with grinder

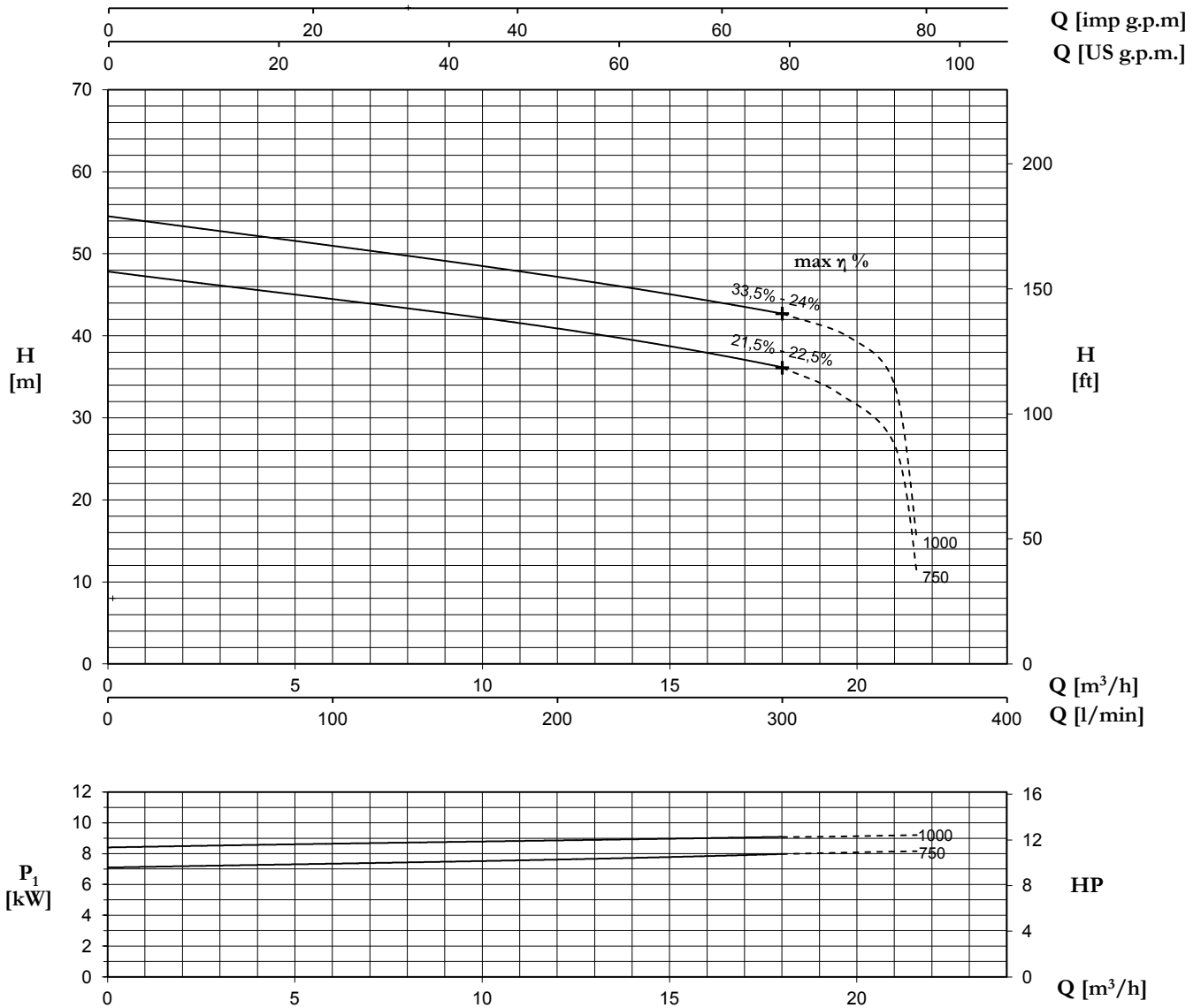

TYPE	AMPERE			
	3x230 V 50 Hz (*)	3x400 V 50 Hz	230/400 V 50 Hz λ / Δ (*)	400/690 V 50 Hz λ / Δ
DTRT 750	-	13,9	24,0	13,9
DTRT 1000	-	15,5	26,8	15,5

(\*) no standard execution

## + max η %

max rendimento idraulico e rispettivo rendimento totale  
 max hydraulic efficiency and respective total efficiency  
 máx rendimiento hidráulico y correspondiente rendimiento total  
 max rendement hydraulique et rendement total

TYPE	P2			P1 (kW)			Q (m³/h - l/min)									
							H (m)									
							0	3	6	9	12	15	18	21	21,6	
3~	(HP)		(kW)	3~	0	50	100	150	200	250	300	350	360			
DTRT 750	7,5	5,5	8,0	3~	47,8	46,2	44,5	42,7	40,8	38,9	36,1	26,7	11,0			
DTRT 1000	10	7,5	9,1	3~	54,6	52,7	51	49,2	47,1	45,1	42,7	34,0	15			

# DTR with grinder

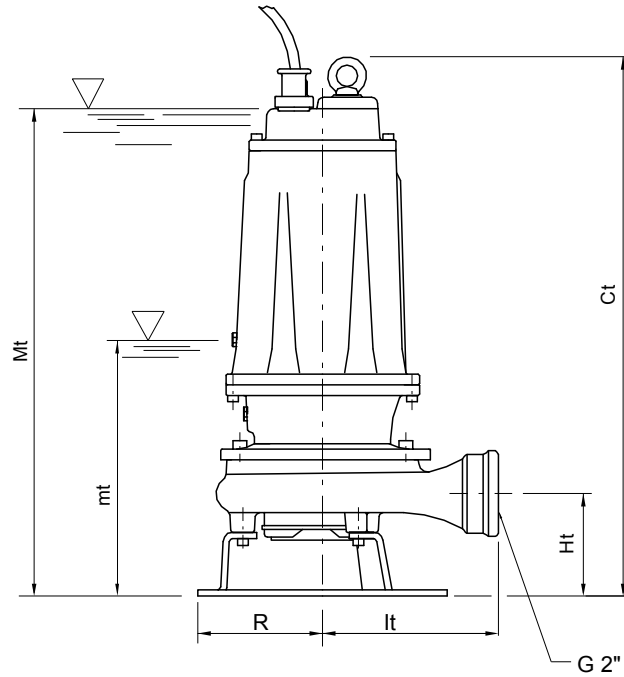

Mt: livello minimo di funzionamento continuo  
 Mt: lowest level for continuous duty  
 Mt: nivel minimo de funcionamiento continuo  
 Mt: niveau minimum de fonctionnement continuu

mt: livello minimo di funzionamento  
 mt: lowest working level  
 mt: nivel minimo de funcionamiento  
 mt: niveau minimum de fonctionnement

TYPE	DIMENSIONS (mm)							DNm	Kg
	Ct	Ht	R	lt	mt	Mt	DNm		
<b>DTR 150-DTRT 150</b>	513	102	117	174	205	475	2" G	38	
<b>DTR 200-DTRT 200</b>	513	102	117	174	205	475	2" G	38,5	
<b>DTRT 300</b>	513	102	117	174	205	475	2" G	38	

TYPE	PROTECTION		CONTROL PANEL		
	1 x 230 V	3 x 400 V	1 x 230 V	3 x 400 V	400 / 690 V
<b>DTR 150</b>	PMLD 15/35-13	PT 20-30-40/4.3-6.8	QSM + 35µF	QSMT 10	-
<b>DTR 200</b>	PMLD 20/50-15	PT 20-30-40/4.3-6.8	QSM + 50µF	QSMT 10	-
<b>DTRT 300</b>	-	PT 20-30-40/4.3-6.8	-	QSMT 10	-
<b>DTRT 400</b>	-	PT 40-50/5.7-9.1	-	QSMT 10	-
<b>DTRT 550</b>	-	PT 55-75/8.6-13.5	-	QSMT 10	-
<b>DTRT 750</b>	-	PT 100/12.5-16.5	-	QSMT 10	QST 7
<b>DTRT 1000</b>	-	PT 125-150/16-21	-	QSMT 15	QST 7

# DTR with grinder

Mt/Mf: livello minimo di funzionamento continuo  
 Mt/Mf: lowest level for continuous duty  
 Mt/Mf: nivel minimo de funcionamiento continuo  
 Mt/Mf: niveau minimum de fonctionnement continuu

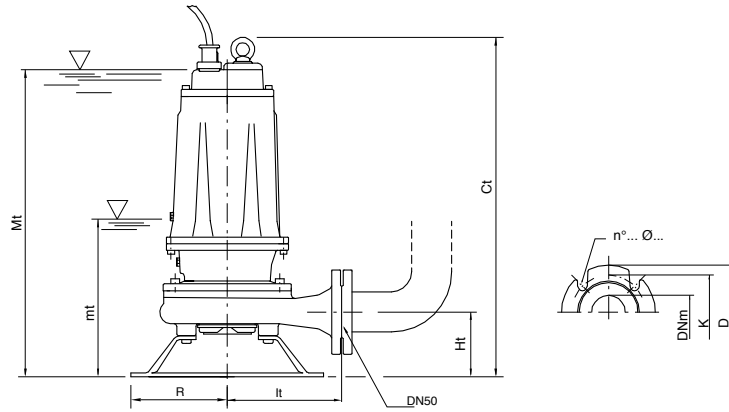

TYPE	DIMENSIONS (mm)								Kg
	Ct	Ht	R	lt	mt	Mt	DNm		
DTRT 400	595	112	160	190	265	550	50	62,5	
DTRT 550	595	112	160	190	265	550	50	65,5	
DTRT 750	680	160	180	250	280	630	65	91,5	
DTRT 1000	680	160	180	250	280	630	65	94,5	

mt/mf: livello minimo di funzionamento  
 mt/mf: lowest working level  
 mt/mf: nivel minimo de funcionamiento  
 mt/mf: niveau minimum de fonctionnement

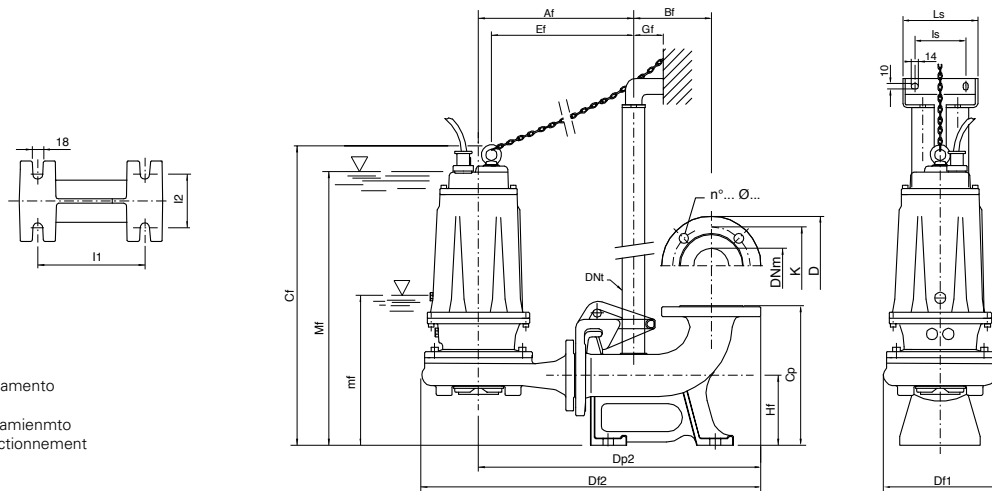

TYPE	DIMENSIONS (mm)																	
	Af	Bf	Cf	Cp	Df1	Df2	Dp2	DNt	Ef	Gf	Hf	I1	I2	Is	Ls	mf	Mf	DNm
DTRT 400/P	300	145	614	260	237	654	538	1" 1/4	269	55	130	200	100	95	140	290	566	50
DTRT 550/P	300	145	614	260	237	654	538	1" 1/4	269	55	130	200	100	95	140	290	566	50
DTRT 750/P	331	145	656	260	279	710	569	1" 1/4	297	55	130	200	100	95	140	290	600	65
DTRT 1000/P	331	145	656	260	279	710	569	1" 1/4	297	55	130	250	100	95	140	290	600	65

Flange UNI PN 10 (mm)			
DNm	K	D	n°... Ø...
50	125	165	4... 18...
65	145	185	4... 18...

TYPE	TRUCK		CONTAINER	
	PALLET (cm)	N° pumps	PALLET (cm)	N° pumps
	DTRT 150-300	85X110X145	18	85X110X190
DTRT 400-550	85X110X170	12	85X110X170	12
DTRT 750-1000	100X120X190	12	100X120X190	12

